

برنامه ریزی حمل و نقل

وزارت علوم، تحقیقات و فناوری



دانشگاه سوره

اجزاء سیستم های حمل و نقل

<http://mnooriamiri.professora.ir>

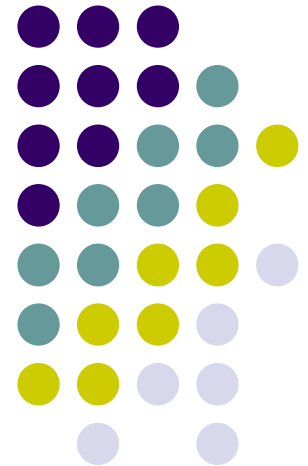

Transportation System Components

- Road users-drivers, pedestrians, bicyclists, and passengers
- Vehicles- private and commercial
- Streets and highways
- Traffic control devices
- The general environment



Road Users

- Physiological–Measurable and Usually Quantifiable
- Psychological–Much more difficult to measure and quantify

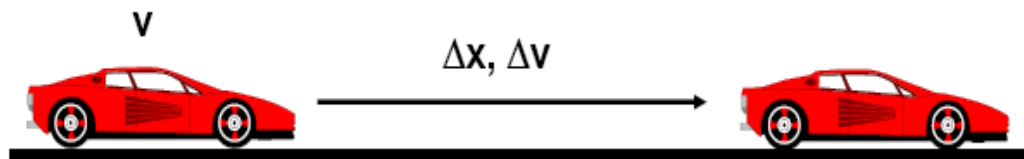

- **Psychological:**
 - x Desired speeds
 - x Desired safety distances
- **Physiological:**
 - x Perception-Reaction time
 - x Visual factors

Diversity (behaviors)

- Drivers and other road users have widely varying characteristics.
- Traffic controls could be easily designed if all drivers reacted to them in exactly the same way.
- Safety could be more easily achieved if all vehicles had uniform dimensions, weights, and operating characteristics.
 - The traffic engineer must deal with elderly drivers as well as 18-year-olds, aggressive drivers and timid drivers, and drivers subject to myriad distractions both inside and outside their vehicles.

Diversity (behaviors)

- Most human characteristics follow the normal distribution
 - A normal distribution defines the proportions of the population expected to fall into these ranges. Because of variation, it is not practical to design a system for “average” characteristics. If a signal is timed, for example, to accommodate the average speed of crossing pedestrians, about half of all pedestrians would walk at a slower rate and be exposed to unacceptable risks.
- Thus, most standards are geared to the “85th percentile” (or “15th percentile”)

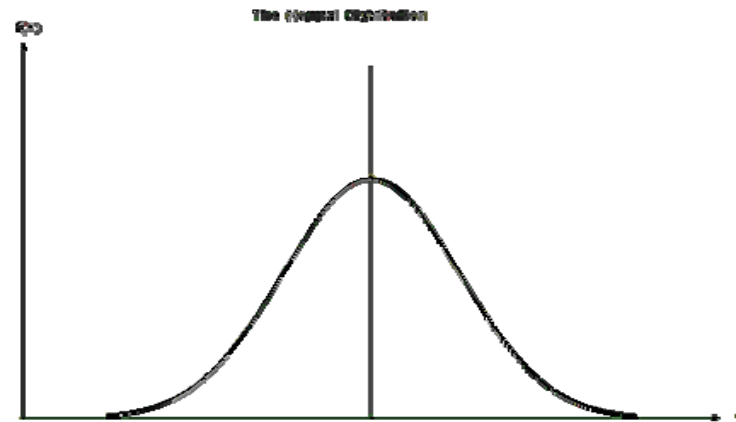

Uniformity for Diversity

- design of roadway systems and traffic controls is in the core of their professional practice.
 - Roadways of a similar type and function should have a familiar “look” to drivers; traffic control devices should be as uniform as possible. Traffic engineers strive to provide information to drivers in uniform ways.

Drivers

- Visual Acuity factors
- Reaction Process
- Hearing
- Physical Strength
- Personality and Psychology

Visual Acuity factors

- The most important characteristic of drivers is their ability to see!
 - Field of Vision
 - Color Blindness
- ... (other factors can be found at table 2.1 of the Textbook)

Field of Vision

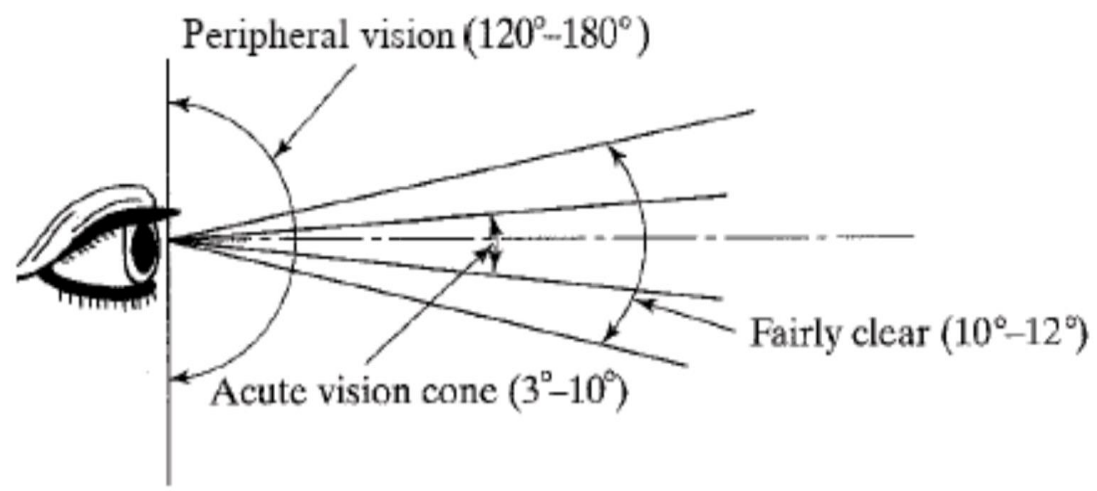

Test Steps

- Find the number 1 in the upper left corner of the picture. Start the timer for 10 seconds.
- Then as quickly as you can, touch the other numbers in numerical order (2, 3, 4, 5, 6, 7, etc.).
- Stop after 10 seconds. Make a note of the last number you touched. This is your score.

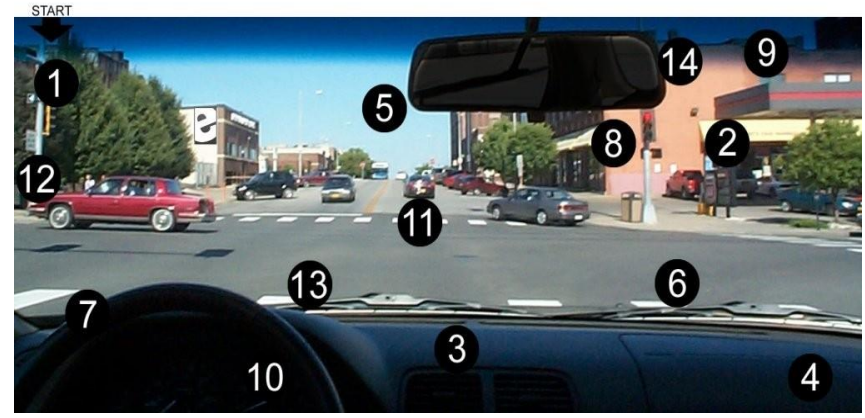



Field of Vision

- *Acute or clear vision cone*- 3° to 10° around the line of sight; legend can be read only within this narrow field of vision.
- *Fairly clear vision cone*- 10° to 12° around the line of sight; color and shape can be identified in this field.
- *Peripheral vision*-*This* field may extend up to 90° to the right and left of the centerline of the pupil, and up to 60° above and 70° below the line of sight.

Stationary objects are generally not seen in the peripheral vision field, but the movement of objects through this field is detected.

Field of Vision

- Objects or other vehicles located in the fairly clear and peripheral vision fields may draw the driver's attention to an important event occurring in that field, such as the approach of a vehicle on an intersection street or driveway or a child running into the street after a ball. Once noticed, the driver may turn his/her head to examine the details of the situation.
- Traffic Signs: Location, Height, Shapes, Colors
- The peripheral vision field narrows, as speed increases, to as little as 100° at 20 mi/h and to 40° at 60 mi/h.



Visual Dificits

- Some of the more common problems involve cataracts, glaucoma, peripheral vision deficits, ocular muscle imbalance, depth perception deficits, and color blindness.
- Unfortunately, one of the most common forms of color blindness involves the inability to discern the difference between red and green.
 - The location of colors on signal heads has long been standardized, with red on the top and green on the bottom of vertical signal heads. On horizontal heads, red is on the left and green on the right.



Perception-Reaction Time

- The second critical driver characteristic is perception-reaction time (PRT)
 - **Detection.** In this phase, an object or condition of concern enters the driver's field of vision, and the driver becomes consciously aware that something requiring a response is present.
 - **Identification.** In this phase, the driver acquires sufficient information concerning the object or condition to allow the consideration of an appropriate response.
 - **Decision.** Once identification of the object or condition is sufficiently completed, the driver must analyze the information and make a decision about how to respond.
 - **Response.** After a decision has been reached, the response is now physically implemented by the driver.

PRT or PIEV

- **P**erception of cue or stimulus
- **I**nterpretation
- **E**valuation of appropriate response (i.e., decision)
- **V**olition or physical response (i.e., reaction)



Factors Affecting PRT

- Age
- Fatigue
- Complexity of Reactions
- Presence of Drugs or Alcohol
- AASHTO Recommendations:
 - **For braking reactions on Highways:**
 - Perception and Reaction Time: 2.5 seconds (90th percentile)
 - **For reaction time to traffic signal**
 - Perception and Reaction Time: 1.0 Second (85th percentile)

Reaction Distance

- The most critical impact of perception-reaction time is the distance the vehicle travels while the driver goes through the process.
- The reaction distance is simply the PRT multiplied by the initial speed of the vehicle.

$$d = 0.278 S.t$$

d = reaction distance, m

t = reaction time, s

S = initial speed of vehicle, km/h



Reaction Distance

- The importance of this factor is illustrated in the following sample problem: A driver rounds a curve at a speed of 50 Km/h and sees a truck overturned on the roadway ahead. How far will the driver's vehicle travel before the driver's foot reaches the brake? Applying the AASHTO standard of 2.5 s for braking reactions:

$$d_r = 0.278 * 50 * 2.5 = 34.75 \text{ m}$$

- The vehicle will travel 35 m (approximately 10-12 car lengths) before the driver even engages the brake. The implication of this is frightening. If the overturned truck is closer to the vehicle than 35 m when noticed by the driver, not only will the driver hit the truck, he or she will do so at full speed-50 Km/h. Deceleration begins only when the brake is engaged-after the perception-reaction process has been completed.

Pedestrian Characteristics

- One of the most critical safety problems in any highway and street system involves the interactions of vehicles and pedestrians.
- Walking Speeds
1 to 1.2 m/s for 85%
- Gap Acceptance
38 m
- Pedestrian Comprehension of Controls



Vehicle Categories

- AASHTO - Four main categories :
 - Passenger cars-all passenger cars, SUVs, minivans, vans, and pickup trucks.
 - Buses-intercity motor coaches, transit buses, school buses, and articulated buses
 - Trucks-single-unit trucks, tractor-trailer, and tractor-semi-trailer combination vehicles
 - Recreational vehicles-motor homes, cars with various types of trailers (boat, campers, motorcycles, etc).

Vehicle Characteristics

- Size
- Weight
- Low-speed turning characteristics
- High-speed turning characteristics
- Braking and deceleration
- Acceleration

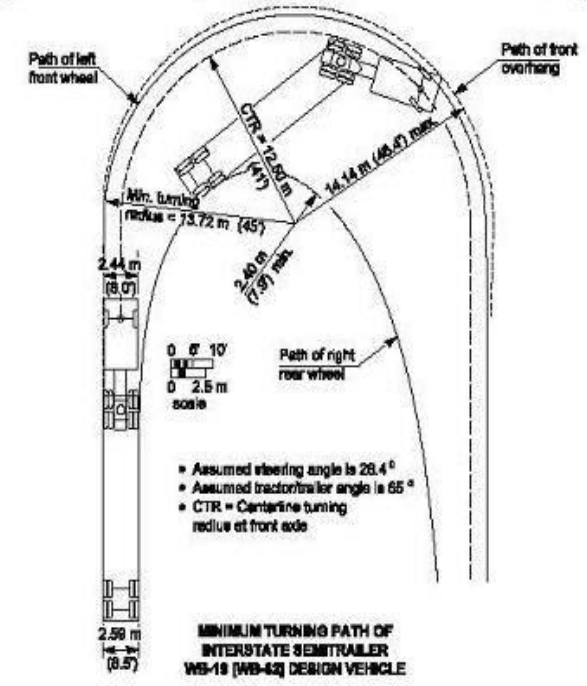
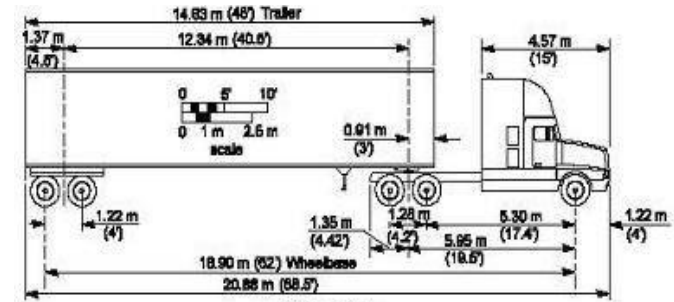

Vehicle dimensions



Width: affects the width of lanes, shoulders, parking facility and capacity of the road

Height: affects the clearance height of structures like over-bridges, under-bridges and electric and other service lines and also placing of signs and signals.

Length: affects the extra width of pavement, minimum turning radius, safe overtaking distance, capacity and the parking facility.

Rear overhang: right/left turn from a stationary point.

Ground clearance: designing ramps and property access and as bottoming out on a crest can stop a vehicle from moving under its own pulling power.

Weight, axle configuration etc

- **Weight:** a major consideration during the design of pavements both flexible and rigid.
- **Axes:** weight of the vehicle is transferred to the pavement through the axles.
- **The power to weight ratio:** determines the length of a positive gradient
- **Turning radius and turning path**
 - The minimum turning radius is dependent on the design and class of the vehicle.
 - **The effective width of the vehicle is increased on a turning.**
This is also important at an intersection, round about, terminals, and parking areas.



Visibility

- **The visibility of the driver:** influenced by the vehicular dimensions, the slope and curvature of wind screens, windscreen wipers, door pillars, etc
 - **visibility is clear even in bad weather conditions like fog, ice, and rain;**
 - **it should not mask the pedestrians, cyclists or other vehicles;**
 - **during intersection maneuvers.**
 - **The side and rear visibility** when maneuvering especially at intersections
 - when the driver adjusts his speed in order to merge or cross a traffic stream.
- Rear vision efficiency** can be achieved by properly positioning the internal or external mirrors.

Turning Movements

- Low-speed turning characteristics
 - ≤ 16 km/h
 - The turning radius can be attained from graphs. (e.g. Fig 2.4)
- High-speed turning characteristics

$$R = \frac{S^2}{127.14(0.01e + f)} \Rightarrow S = \sqrt{127.14 R(0.01e + f)}$$

S : Speed km/h

R : Curve Radius m

e : Superelevation rate %

f : Coefficient of side friction

Turning Movements

- Coefficient of side friction in wet pavements

Speed km/h	48	64	80	97	113
f	0.16	0.15	0.14	0.12	0.1

- The Example can be found at page 30 of the textbook



Braking Characteristic

- Braking Distance

$$d_b = \frac{S_i^2 - S_f^2}{254.28 (F \pm \% G)}$$

d_b : Braking Distance m

S_i : Initial Speed m/s

S_f : Final Speed m/s

a : Deceleration rate m/s^2

$F = a/g$ ($g=9.81 m/s^2$)

G : Grade %



Total Stopping Distance

$$d = d_r + d_b = 0.278 S.t + \frac{S_i^2 - S_f^2}{254.28 (F \pm \% G)}$$

- Safe Stopping Sight Distance
- Decision Sight Distance
- Change (Yellow) and Clearance (All Red) Intervals for a Traffic Signal



Safe Stopping Sight Distance

- One of the most fundamental principles of highway design is that the driver must be able to see far enough to avoid a potential hazard or collision. Thus, on all roadway sections, the driver must have a sight distance that is at least equivalent to the total stopping distance required at the design speed.
- The Example can be found at page 33 of the textbook

Decision Sight Distance

- there are some sections that should provide greater sight distance to allow drivers to react to potentially more complex situations than a simple stop.
- AASHTO recommends that decision sight distance be provided at interchanges or intersection locations where unusual or unexpected maneuvers are required; changes in cross-section such as lane drops and additions, toll plazas, and intense-demand areas where there is substantial “visual noise” from competing information (e.g., control devices, advertising, roadway elements).



Decision Sight Distance

$$d = 0.278 (t_r + t_m) S_i$$

d = Decision Sight Distance, m

t_r = reaction time for appropriate avoidance maneuver, s

t_m = maneuver time, s

S_i = initial speed of vehicle, km/h

Decision Sight Distance (Table 2.6 of Textbook)

Design Speed (mi/h)	Assumed Maneuver Time (s)	Decision Sight Distance for Avoidance Maneuver (ft)				
		A (Equation 2-9)	B (Equation 2-9)	C (Equation 2-10)	D (Equation 2-10)	E (Equation 2-10)
Reaction Time (s)		3	9.1	11.2	12.9	14.5
30	4.5	219	488	692	767	838
40	4.5	330	688	923	1023	1117
50	4.0	460	908	1117	1242	1360
60	4.0	609	1147	1341	1491	1632
70	3.5	778	1406	1513	1688	1852
80	3.5	966	1683	1729	1929	2117

A: Stop on a rural road
 B: Stop on an urban road
 C: Speed/path/direction change on a rural road
 D: Speed/path/direction change on a suburban road
 E: Speed/path/direction change on an urban road



Acceleration characteristics

- **The acceleration capacity of vehicle is dependent on its mass, the resistance to motion and available power.**
 - **Heavier vehicles have lower rates of acceleration than passenger cars.**
 - **The difference in acceleration rates becomes significant in mixed traffic streams.** (For example, heavy vehicles like trucks will delay all passengers at an intersection)
 - **The presence of upgrades (slope +) Trucks are forced to decelerate on grades because their power is not sufficient to maintain their desired speed.**
- As trucks slow down on grades, long gaps will be formed in the traffic stream which cannot be efficiently filled by normal passing maneuvers.**



Reading

- *Traffic Engineering*, Roess, Prassas, McShane